

# High functionality/High performance Digital Force Gauge ZT Series Separate Sensor Model

Separate sensor model of high performance digital force gauge ZT series.  
Wide range of load cell designed to meet varied test applications.  
Various data output for external equipment control.



### Use with...

DPU series load cell to mount on equipment.



LM series load cell for measuring in limited space.



WP series load cell for measuring in wet environment.





DM series load cell for measuring the closure force of automatic doors.



\*LEFT: ZTA with DPU-50N

\*Load cells are calibrated independently to each display unit. They are NOT interchangeable.

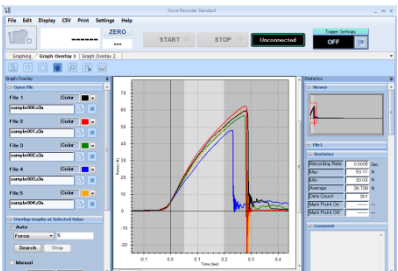
### [Features]

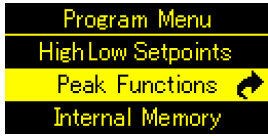
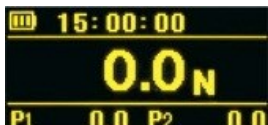
Fast Sampling & Accurate Results	Direct data storing to USB	Clear Display
Fast sampling speed of max. 2000 data/sec and fast USB connection provides smooth graph drawing. (Optional software required)	Continuous data saved directly to USB memory stick (ZTA series only)	Bright Organic EL display shows multiple values (date and time, the number of memory, comparator value and more.)
		 

## [ZT series Specifications]

You can select from 2 types (ZTA or ZTS) in accordance with your use.

Model	ZTA	ZTS
Feature	Advanced model with various functions such as data saving in USB memory stick, displacement I/O and more.	Standard model with the same benefit in performance as ZTA series but reduced functionality.
Accuracy	+/-0.2%F.S.+/-1digit	
Unit of measurement(*1)	N, kgf, lbf (*2)	
Display	4-digit Organic EL	
Display update	16 / sec	
Sampling rate	2000 / sec at maximum (*3)	
Battery	8 hours (2 hours charge)(*4) The battery is more consumed when connected to USB memory stick or linear scale.	
Safe overload rating	Approx.200%F.S.	
Operating environment	Temperature: 0 to +40 degree Celsius Humidity: 20 to 80%RH	
Function	Customized display (header and footer), Peak hold (tension and compression), Internal 1000 points data memory, Comparator (judgment of OK or NG), Reversible display, Sign inversion, Zero clear timer, +NG alarm, Off timer (auto power off), Dumping, Calendar display, Setting lock	
	1 <sup>st</sup> /2 <sup>nd</sup> peak, Displacement detection at force peak, Displacement 0 reset at selected force	-
Output	USB, RS232C, Mitutoyo digimatic (*5), 2 VDC analog output (D/A), Comparator 3 steps (-NG/OK/+NG)	
	Sub comparator 2 steps (output of low or high judgment)	-
Overload warning	Approx.110%F.S. (Warning message and alarm)	
External connecting switch	SEND (a point of contact holding), Zero reset, Peak ON/OFF setting	
Weight	Indicator: Approx.490g (Load cell: Please refer to each load cell's specifications)	
Dimensions	Please refer to dimensions.	
Accessory(*6)	AC adapter, Inspection certificate, CD driver (including simple software for data log), Attachments (The set of attachments varies according to range.), USB cable, Carrying case.	
	Adapter for USB memory stick(*6)	-

\*1 These are the specifications for international model. Please note that this unit is different from Japanese domestic model and international one.

\*2 [N indication] The indication of 2N and 5N models is mN or N. The indication of 1000N,2500N and 5000N model is N or kN.

[kgf indication] The indication of 2N and 5N models is gf.

[lbf indication] The indication of 2N and 5N models is ozf.

\*3 When you save data in USB memory stick, the sampling rate is selectable among 1, 50 and 100/sec.

\*4 The battery is more consumed when connected to USB flash drive or a linear scale.

\*5 Not always available for Mitutoyo digimatic products.

\*6 USB memory stick is not included.

## [Sensor Separate Models]

Select a display and a sensor;

Example of combination:

Display + Sensor (Load cell)	Model
ZTA series + DPU-50N	ZTA-DPU-50N
ZTS series + LM-2000N	ZTS-LM-2000N

**[DPU Models]**

Model		Capacity	Display	Resolution
ZTA-DPU-2N	ZTS-DPU-2N	2N(200gf)	2.000N/2000mN(200.0gf)	0.001N/1mN(0.1gf)
ZTA-DPU-5N	ZTS-DPU-5N	5N(500gf)	5.000N/5000mN(500.0gf)	0.001N/1mN(0.1gf)
ZTA-DPU-10N	ZTS-DPU-10N	10N(1kgf)	10.00N(1.000kgf)	0.01N(0.001kgf)
ZTA-DPU-20N	ZTS-DPU-20N	20N(2kgf)	20.00N(2.000kgf)	0.01N(0.001kgf)
ZTA-DPU-50N	ZTS-DPU-50N	50N(5kgf)	50.00N(5.000kgf)	0.01N(0.001kgf)
ZTA-DPU-100N	ZTS-DPU-100N	100N(10kgf)	100.0N(10.00kgf)	0.1N(0.01kgf)
ZTA-DPU-200N	ZTS-DPU-200N	200N(20kgf)	200.0N(20.00kgf)	0.1N(0.01kgf)
ZTA-DPU-500N	ZTS-DPU-500N	500N(50kgf)	500.0N(50.00kgf)	0.1N(0.01kgf)
ZTA-DPU-1000N	ZTS-DPU-1000N	1000N(100kgf)	1000N/1.000kN(100.0kgf)	1N/0.001kN(0.1kgf)
ZTA-DPU-2000N	ZTS-DPU-2000N	2000N(200kgf)	2000N/2.000kN(200.0kgf)	1N/0.001kN(0.1kgf)
ZTA-DPU-5000N	ZTS-DPU-5000N	5000N(500kgf)	5000N/5.000kN(500.0kgf)	1N/0.001kN(0.1kgf)
ZTA-DPU-10kN	ZTS-DPU-10kN	10kN(1000kgf)	10.00kN(1000kgf)	0.01kN(1kgf)
ZTA-DPU-20kN	ZTS-DPU-20kN	20kN(2000kgf)	20.00kN(2000kgf)	0.01kN(1kgf)

**[LMU Models]**

Model		Capacity	Display	Resolution
ZTA-LMU-50N	ZTS-LMU-50N	50N(5kgf)	50.00N(5.000kgf)	0.01N(0.001kgf)
ZTA-LMU-100N	ZTS-LMU-100N	100N(10kgf)	100.0N(10.00kgf)	0.1N(0.01kgf)
ZTA-LMU-200N	ZTS-LMU-200N	200N(20kgf)	200.0N(20.00kgf)	0.1N(0.01kgf)
ZTA-LMU-500N	ZTS-LMU-500N	500N(50kgf)	500.0N(50.00kgf)	0.1N(0.01kgf)

**[LU Models]**

Model		Capacity	Display	Resolution
ZTA-LU-50N	ZTS-LU-50N	50N(5kgf)	50.00N(5.000kgf)	0.01N(0.001kgf)
ZTA-LU-100N	ZTS-LU-100N	100N(10kgf)	100.0N(10.00kgf)	0.1N(0.01kgf)
ZTA-LU-200N	ZTS-LU-200N	200N(20kgf)	200.0N(20.00kgf)	0.1N(0.01kgf)
ZTA-LU-500N	ZTS-LU-500N	500N(50kgf)	500.0N(50.00kgf)	0.1N(0.01kgf)
ZTA-LU-1000N	ZTS-LU-1000N	1000N(100kgf)	1000N/1.000kN(100.0kgf)	1N/0.001kN(0.1kgf)
ZTA-LU-2000N	ZTS-LU-2000N	2000N(200kgf)	2000N/2.000kN(200.0kgf)	1N/0.001kN(0.1kgf)

**[LM Models]**

Model		Capacity	Display	Resolution
ZTA-LM-10N	ZTS-LM-10N	10N(1kgf)	10.00N(1.000kgf)	0.01N(0.001kgf)
ZTA-LM-20N	ZTS-LM-20N	20N(2kgf)	20.00N(2.000kgf)	0.01N(0.001kgf)
ZTA-LM-50N	ZTS-LM-50N	50N(5kgf)	50.00N(5.000kgf)	0.01N(0.001kgf)
ZTA-LM-100N	ZTS-LM-100N	100N(10kgf)	100.0N(10.00kgf)	0.1N(0.01kgf)
ZTA-LM-200N	ZTS-LM-200N	200N(20kgf)	200.0N(20.00kgf)	0.1N(0.01kgf)
ZTA-LM-500N	ZTS-LM-500N	500N(50kgf)	500.0N(50.00kgf)	0.1N(0.01kgf)
ZTA-LM-1000N	ZTS-LM-1000N	1000N(100kgf)	1000N/1.000kN(100.0kgf)	1N/0.001kN(0.1kgf)
ZTA-LM-2000N	ZTS-LM-2000N	2000N(200kgf)	2000N/2.000kN(200.0kgf)	1N/0.001kN(0.1kgf)
ZTA-LM-5000N	ZTS-LM-5000N	5000N(500kgf)	5000N/5.000kN(500.0kgf)	1N/0.001kN(0.1kgf)
ZTA-LM-10kN	ZTS-LM-10kN	10kN(1000kgf)	10.00kN(1000kgf)	0.01kN(1kgf)
ZTA-LM-20kN	ZTS-LM-20kN	20kN(2000kgf)	20.00kN(2000kgf)	0.01kN(1kgf)

**[Load Cells ]**

Model	DPU series	SW series	LMU series	LU series
Feature	Standard - Wide Use	Water-proof	Small Size	Small Size - Wide Use
Force	Tension/Compression	Tension/Compression	Tension/Compression	Tension/Compression
Capacity	2N to 20kN	100N to 20kN	50N to 500N	50N to 2000N
Accuracy	+/- 0.2%F.S.	+/- 0.5%F.S.	+/- 1%F.S.	+/- 1%F.S.
Cable Length	Up to 500N:2m 1000N to 20kN:3m	Up to 5000N: 4m(Curl cord) 10kN to 20kN: 5m	2m	3m
Dimensions	From Approx. W58xD21xH71 up to Approx. W88xD40xH155mm	Approx. W40xD20xH40 to Approx. W80xD25xH80mm	Approx. φ18xH25mm	Approx. φ28xH35mm
Thread	Up to 500N: M6P1 (Male) 1000N to 5000N: M10P1.5 (Male) 10kN to 20kN: M18P1.5 (Length 22mm Female)	Up to 200N: M6P1 500N to 1000N: M8P1.25 2000N to 5000N: M10P1.5 10kN to 20kN: M16P2.0 (Female)	M5P0.8 (Male)	M8P1.25 (Length 8mm Female)
Image				

Model	LM series	LC series	DD series	LMT series
Feature	Thin & Round	Round & Precise	High Accuracy & Water-proof	Low/High Temperature Resistance (-40 to 130 degree Celsius)
Force	Compression	Compression	Compression	Compression
Capacity	10N to 20kN	500N to 20kN	5000N to 20kN	1000N
Accuracy	+/- 1 to 2.5%F.S.	+/- 0.5%F.S.	+/- 0.5%F.S.	+/- 5%F.S.
Cable Length	2m	3m	5m	2m
Dimensions	Approx.φ12xH4 to φ21xH10mm	Approx.φ50xH25mm	Approx.φ94xH48mm	Approx.φ14xH4.3mm
Image				

Model	PN series	PK2 series	DM series
Feature	Pen type	For car foot brakes	For door
Image			

Model	ZD series	ZU series	ZW1 series
Feature	Small Size - High capacity	Two rod ends	Crane scale type
Image			

\*For further details, please refer to the specification sheet of each load cell.

[Accessories]

<p>Data logger Simple software ZT-Logger</p>	<p><b>Main functions</b></p> <ul style="list-style-type: none"> <li>- Captures peak data (*1)</li> <li>- Captures continuous data (10 data /sec) (*1)</li> <li>- The recall of memory data (*1)</li> <li>- Saves data in CSV format</li> <li>- Prints out reports</li> </ul> <p><b>Operating environment</b></p> <ul style="list-style-type: none"> <li>- OS: Windows XP/Vista/7/8/8.1 (32bit/64bit for 7/8/8.1)</li> <li>- CPU: more than 1GHz</li> <li>- Memory: more than 1GB</li> <li>- Hard disk : more than 2GB</li> <li>- .NET Framework4 later recommended</li> </ul> <p>*1 Available data: Force / Displacement (Must be combined with a test stand having linear scale) / Time</p> <p>*2 Please note that the software may not work in all environmental combinations.</p>	
<p>Attachment</p>	<p><b>Accessory attachment</b></p> <p>The following attachments are included when ZT series separate model and a DPU series load cell are purchased together.</p> <p>2N-100N: A-1 to 8 200N-1000N: S-1(SR-1) to 8 2500N-5000N: B-1 to 8</p> <p>*Please refer to each specification of attachment for more information.</p>	<p>Accessory attachments' shape (an excerpt)</p> <p>S-1 Small hook    S-2 Disk shaped    S-3 Conical shaped    S-6 Extension rod    S-7 Large hook</p>

[Option]

Option	Explanation	Model
Analog voltage (Sensor raw data)	To output sensor data as fast analog voltage without conversion. *The speed is higher than D/A (standard), but there are demerits at the same time that zero reset is not possible, and there are may be signal noise. *CB-118 cable is necessary.	-AN



## [Application of Force Gauge]

ZT series enable

1. Controlling external equipment according to force value. (e.g. To stop or change operation of machine at a selected force value.)
  2. Adding load at a certain force value. (e.g. To maintain sample at a chosen force value.)
  3. Producing inspection device synchronized with work process. (e.g. To improving efficiency of inspection process.)
  4. Finding inferior goods earlier with comparator (judgment of acceptance or rejection) function.(e.g. To do quality control thoroughly)
- > Please contact us or our distributor in your country for further information.

## [Related Products]

Graphing Software: Force-Recorder																															
	You can select from 3 grades.																														
	<table border="1"> <thead> <tr> <th>Main functions</th> <th>Professional</th> <th>Standard</th> <th>Light</th> </tr> </thead> <tbody> <tr> <td>Force-time graphing</td> <td>✓</td> <td>✓</td> <td>✓</td> </tr> <tr> <td>Sampling rate: Max. 2000/sec</td> <td>✓</td> <td>✓</td> <td>✓</td> </tr> <tr> <td>Force gauge function setting</td> <td>✓</td> <td>✓</td> <td>✓</td> </tr> <tr> <td>Data storage in CSV format</td> <td>✓</td> <td>✓</td> <td>✓</td> </tr> <tr> <td>5 graphs at maximum can be displayed in a table</td> <td>✓</td> <td>✓</td> <td>N/A</td> </tr> <tr> <td>Force-displacement graphing</td> <td>✓</td> <td>N/A</td> <td>N/A</td> </tr> </tbody> </table>	Main functions	Professional	Standard	Light	Force-time graphing	✓	✓	✓	Sampling rate: Max. 2000/sec	✓	✓	✓	Force gauge function setting	✓	✓	✓	Data storage in CSV format	✓	✓	✓	5 graphs at maximum can be displayed in a table	✓	✓	N/A	Force-displacement graphing	✓	N/A	N/A		
	Main functions	Professional	Standard	Light																											
	Force-time graphing	✓	✓	✓																											
	Sampling rate: Max. 2000/sec	✓	✓	✓																											
Force gauge function setting	✓	✓	✓																												
Data storage in CSV format	✓	✓	✓																												
5 graphs at maximum can be displayed in a table	✓	✓	N/A																												
Force-displacement graphing	✓	N/A	N/A																												
*Professional version needs ZTA and a test stand with linear scale.																															
*Please refer to each specification for further information.																															
Printer:DP-1VR	Optional Handles: FOH-1	Battery: BP-308																													
Prints indicated values and data in internal memory. CB-308 cable is necessary.	You can grip handles firmly so it becomes easier to apply high load force steadily.	Battery for replacement.																													
	<b>eZ-Connect series Sensor-interchangeable Amplifier eZT</b> eZT is an amplifier which enables to connect to various eZ-Connect load cells of your choice. - Useful for different types of measurement; small and large force values, or compression and torque.  *The amplifier and the load cell are not calibrated (actual loading calibration) together therefore the inspection certificate is not included. Please calibrate them or ask us for calibration service. *The accuracy of load cell is dependent on the model. Please refer to each specification sheet for details.																														

[Related Cable]

Model	Explanation	Purpose of use
CB-108	Analog cable	To connect to a multi meter, oscilloscope.
CB-118	Analog cable (For -AN option)	To connect to a multi meter, oscilloscope.
CB-208	RS232C cable	To connect to a PC having its own system
CB-308	Digimatic cable	To connect to a printer DP-1VR
CB-508	Test stand option cable (For MX)	To connect to a test stand to enable force control or overload prevention functions.
CB-518	Test stand option cable (For MX2,EMX)	To connect to a test stand to enable force control or overload prevention functions.
CB-718	Test stand connection cable for displacement measurement (For MX2-FA)	To connect to a test stand having length meter to enable force-displacement measurement.
CB-728	Test stand connection cable for displacement measurement (For EMX-FA)	To connect to a test stand having length meter to enable force-displacement measurement.
CB-908	Open end connection cable	Output cable for loose wire 37 pin (Useful for connection with unique equipment.)

[Dimensions: Display]

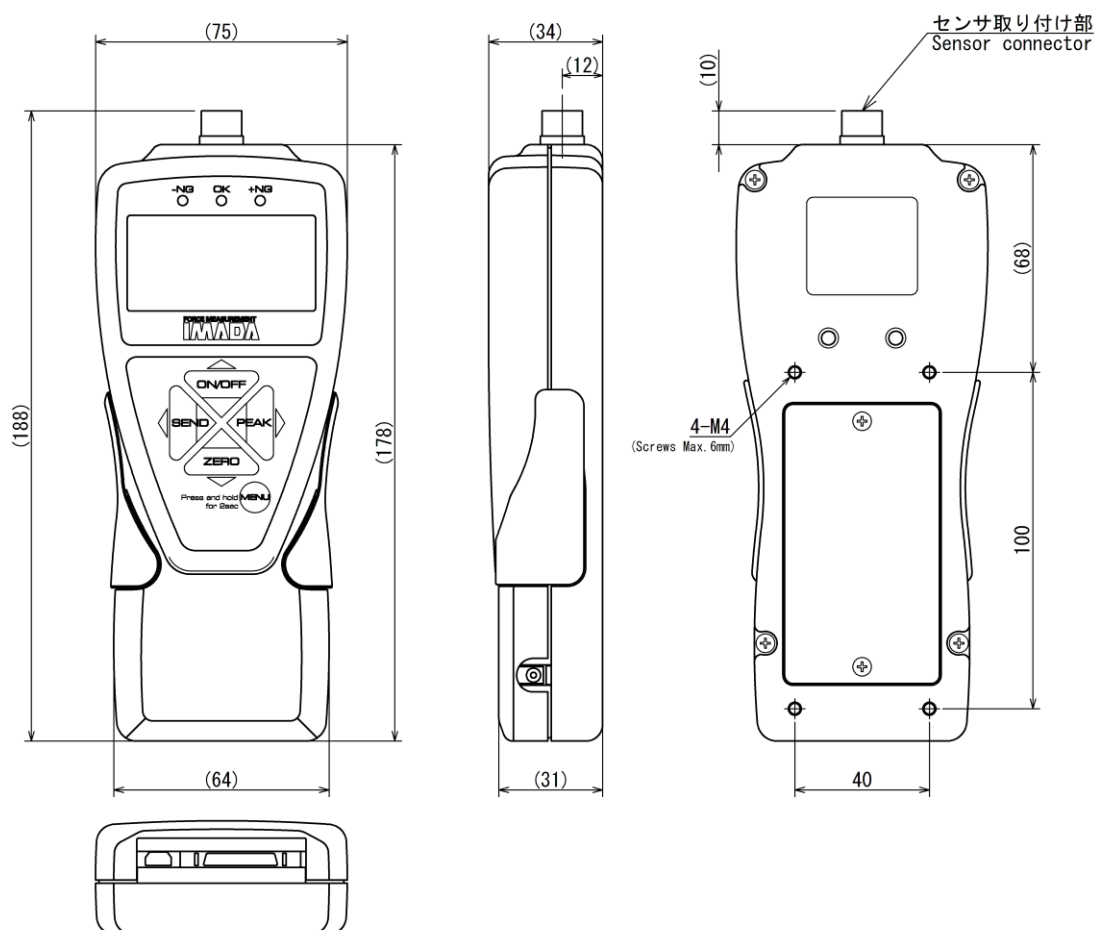

\* Please see the specifications of each load cell for its dimensions.

### **[Calibration Certificate]**

We offer calibration certificate at extra charge.

\*Please contact us or our distributor in your country for more information.

### **[Cautions]**

- The contents may be changed without prior notice.
- All products are designed for measurement purpose only.
- Do not copy and use this content without authority.
- Please note that the capacity is dependent on the displayed unit. Please contact us for details.